

CONTENTS	QTY.
LOOP LATCH; \varnothing 3/8" LOW CARBON STEEL WIRE	1
SCREWS; 5/16" X 1-1/2" HEX LAG	2
POLY BAG WITH INSTRUCTIONS	1

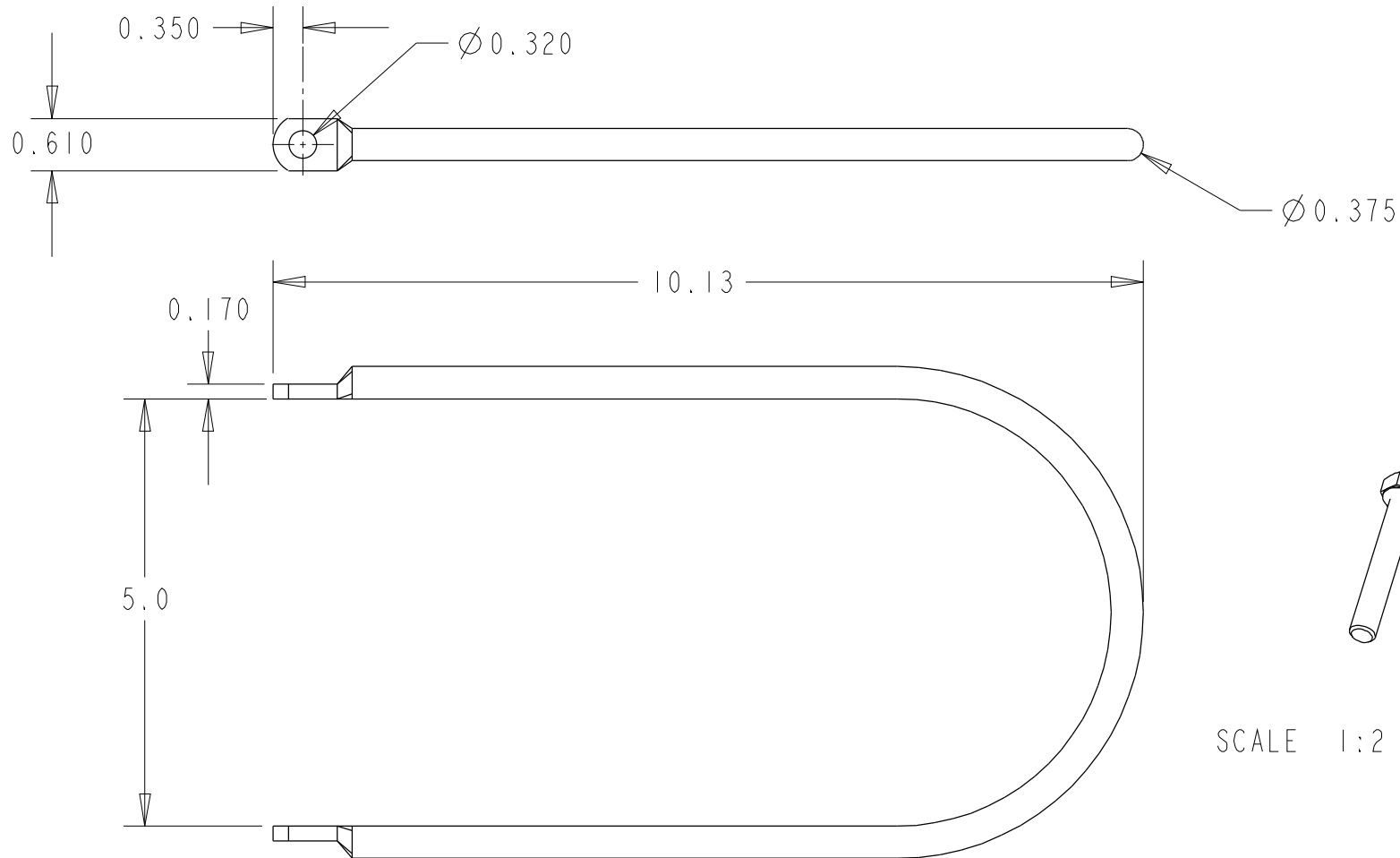

SCALE 1:2

NOTES:

1. DIMENSIONS SHOWN ARE NOMINAL.
2. FINISH: ZINC PLATED, HPC; UNLESS OTHERWISE STATED. FASTENERS MUST BE HPC SEAL COATED.

REVISED 12/08/2009, JDG

D&D 220001 ROUND RAIL LOOP LATCH