

| CONTENTS   | QTY. |
|--|------|
| LOOP LATCH; $\varnothing$ 3/8" LOW CARBON STEEL WIRE | 1    |
| SCREWS; 5/16" X 2" HEX LAG                           | 2    |
| POLY BAG WITH INSTRUCTIONS                           | 1    |

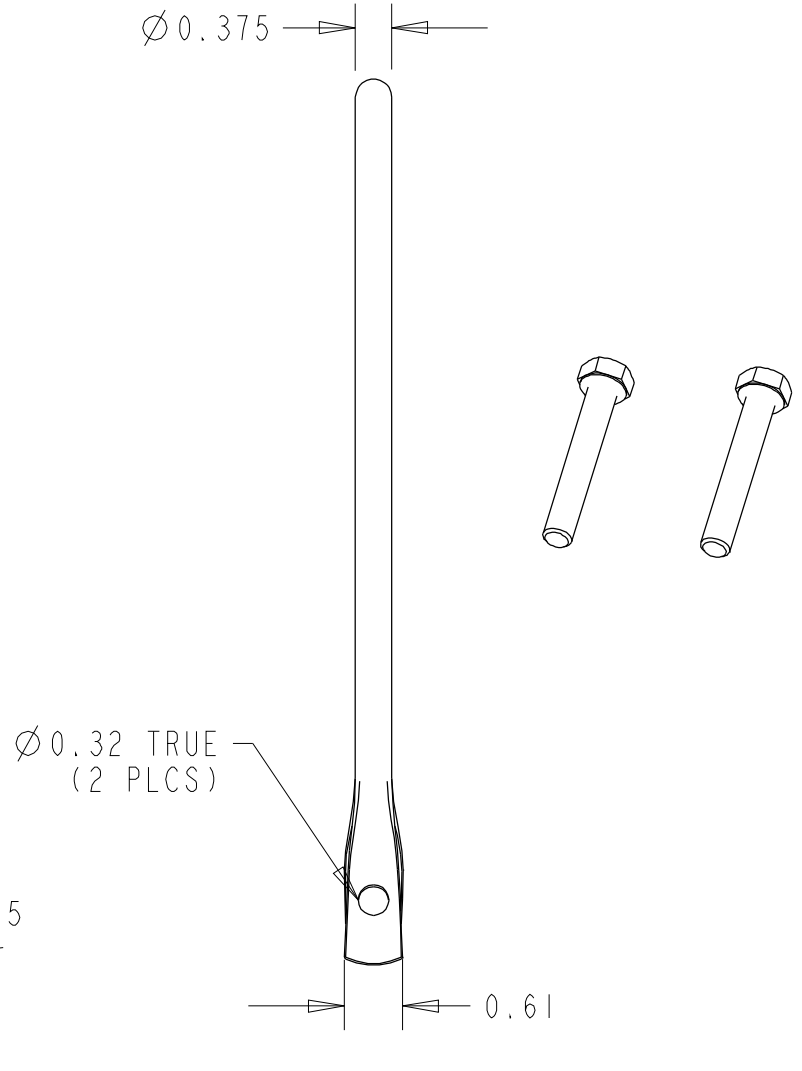
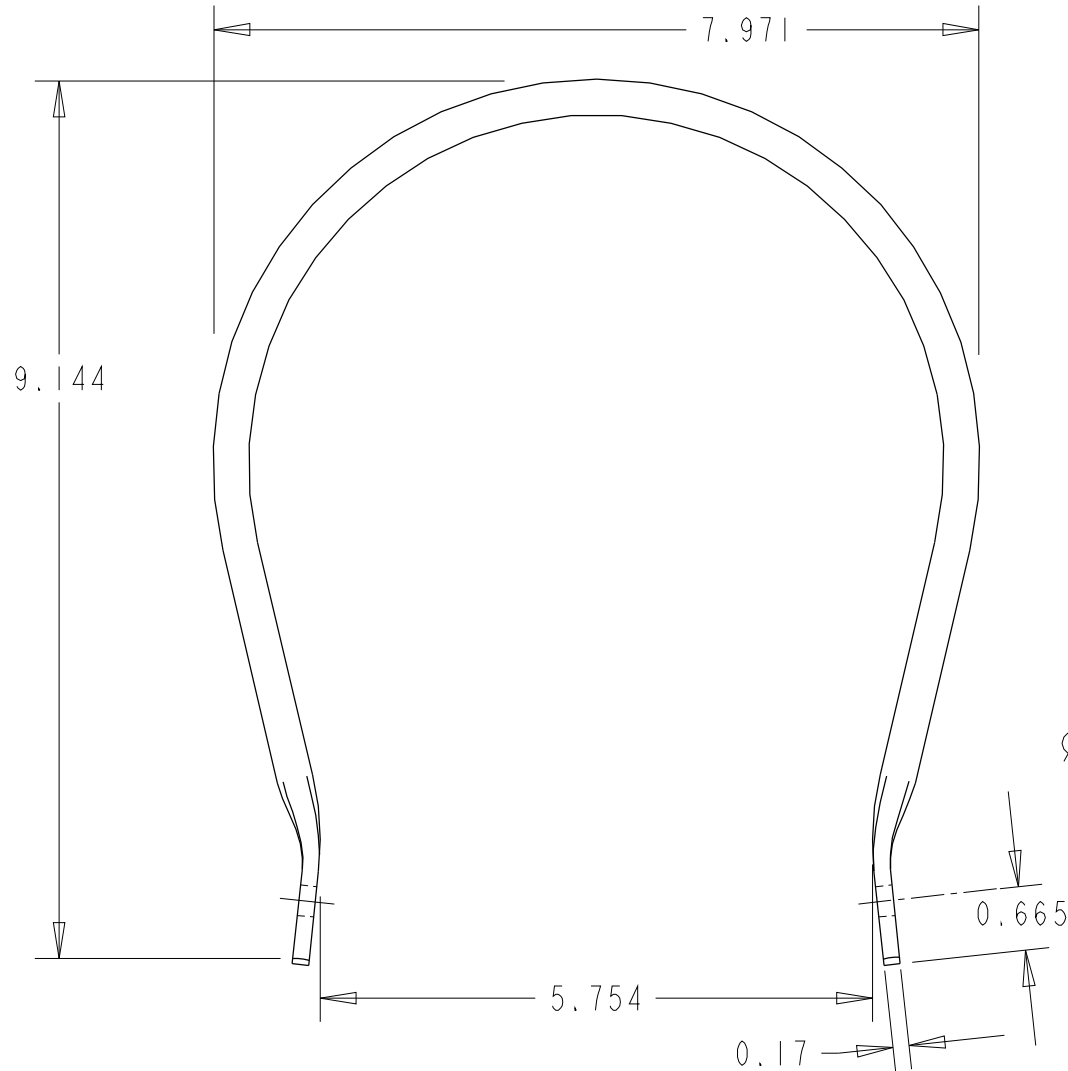

NOTES:

1. DIMENSIONS SHOWN ARE NOMINAL.
2. FINISH: ZINC PLATED, HPC; UNLESS OTHERWISE STATED. FASTENERS MUST BE HPC SEAL COATED.

REVISED 12/08/2009, JDG

D&D 220002 SPLIT RAIL LOOP LATCH