

| CONTENTS | QTY. |
|--|------|
| HINGE PAD; POWDER COATED BLACK | 2 |
| HINGE STRAP; POWDER COATED BLACK | 2 |
| HINGE PIN, $\varnothing 8.5\text{mm}$ X 4.75" LONG | 2 |
| SCREWS, 5/16" X 2" HEX HEAD LAG | 12 |
| POLY BAG WITH PRINTED INSTRUCTIONS | 1 |

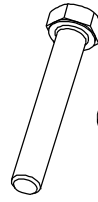

6 SCREWS PER HINGE

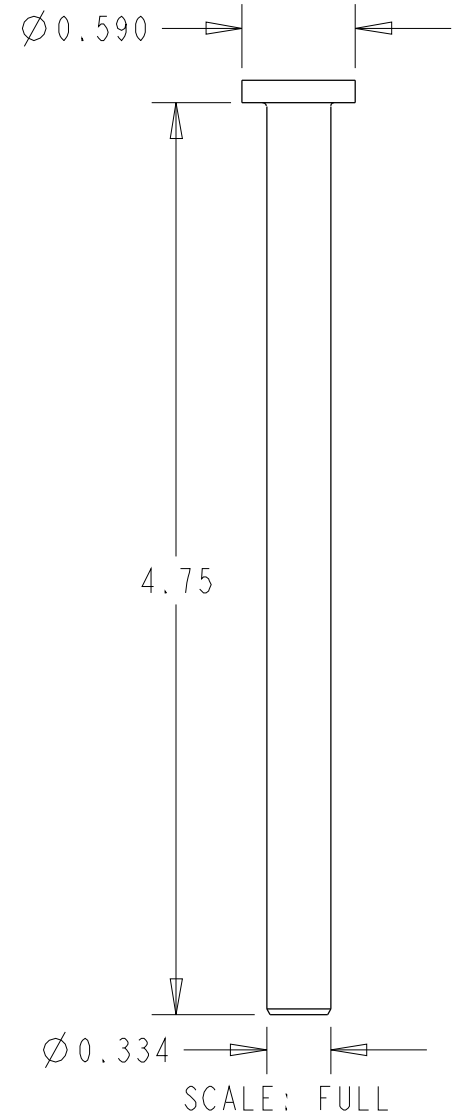
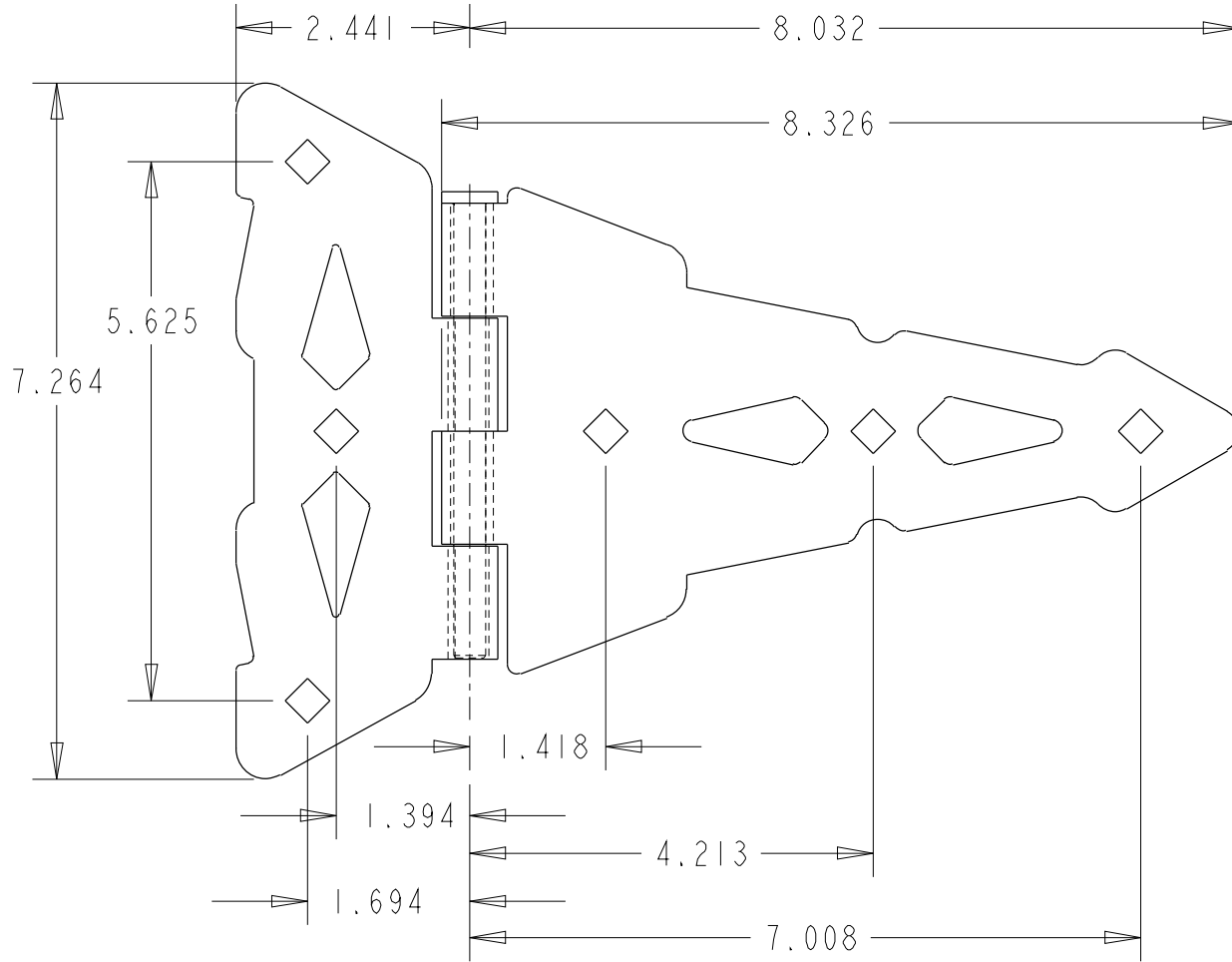

NOTES:

- DIMENSIONS SHOWN ARE NOMINAL.
- FASTENERS MUST BE HPC SEAL COATED WITH BLACK POWDERCOATED HEADS PER APPROVED SAMPLE.

SCALE: 1=2

NOTES:

- HINGE MATERIAL: 0.094" LOW CARBON STEEL
- HINGE PIN TO BE LUBRICATED WITH APPROVED GREASE.

REVISED 12/04/2009, JDG

D&D 310007 TEE HINGE